

# INSIDE FLANGE CONICAL POINT

## MODEL P-14006

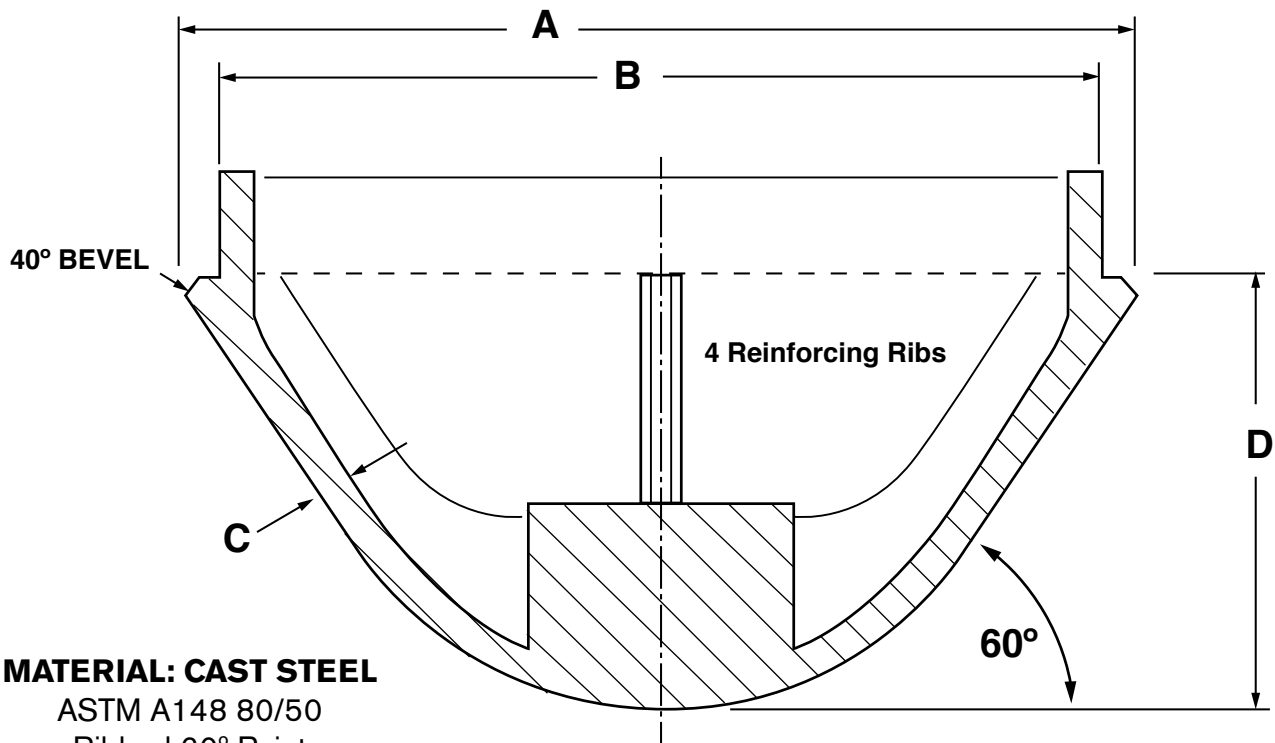

**MATERIAL: CAST STEEL**  
 ASTM A148 80/50  
 Ribbed 60° Point

NORMAL FOUNDRY TOLERANCES APPLY

PIPE OD	A	B	C	D	wt
8-5/8"	8-5/8"	7-1/2"	1/2"	5"	22#
10-3/4"	10-3/4"	9-7/16"	1/2"	5-1/2"	30#
12"	12"	10-3/4"	1/2"	6-1/2"	47#
12-3/4"	12-3/4"	11-9/16"	1/2"	6-1/2"	56#
14"	14"	12-3/4"	1/2"	8"	59#
16"	16"	14-3/4"	1/2"	9"	67#
18"	18"	16-3/4"	1/2"	11"	106#

### Installation Instructions

1. Hold conical point in close contact with the end of a square cut pile.
2. Place a 5/16" partial penetration single-bevel groove weld along the entire circumference of the pile/shoe interface utilizing an E70XX low hydrogen electrode or equivalent filler material.

Note: Place a 3/8" bevel at 40 degrees on the pipe if the point is not pre-beveled. AWS standard tolerances for bevel angle and root face apply.



**ASSOCIATED PILE  
& FITTING**

45 Samworth Road, Clifton, NJ 07014  
 Tel: 973-773-8400  
 Fax: 973-773-8442  
 email: [apf@associatedpile.com](mailto:apf@associatedpile.com)  
[www.associatedpile.com](http://www.associatedpile.com)  
 Call Toll Free: 800-526-9047